

PULLING CYLINDERS, IN STEEL AND ALUMINIUM

SPRING RETURN

FEATURES

Range in steel

Have a thread on the body, on the rod and in the base to mount the proper accessories.
The internal and external nitriding treatment gives them a good resistance to wear and corrosion.

Range in aluminium

Manufactured completely in aluminium (apart from the rod) these cylinders have been given an anodizing treatment to protect them against corrosion.
They have a bellows to protect the rod and from 30 tonne models carrying handles.

OPERATIONAL AREAS

Range in steel

Used in assembling, building and in laboratories to test the resistance of materials.

Range in aluminium

These are used in shipbuilding and in steel structural works to pull together plates, or prefabricated parts which have to be welded together.



ACCESSORIES



 ZAS Set of eyelets for series N cylinders.



These cylinders can be used with the **PL** lightweight hand pumps with which they make a handy hydraulic set.



p. 49

ACCESSORIES: ZAS EYELETS SET

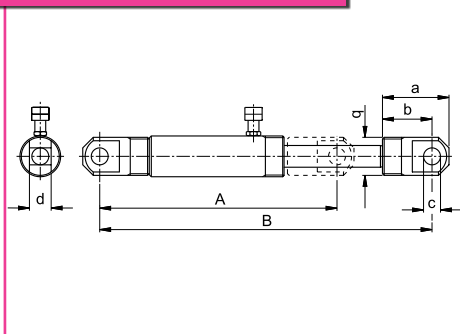

For use with

MODEL

Closed height

Extended height



				a mm	b mm	c mm	d mm	q mm
		A	B					
CMT2N127	ZAS2	290	417	62	46	16	16	M35x1,5
CMT5N140	ZAS5	403	543	98	73	25	32	M56x2
CMT10N150	ZAS10	394	544					

PULLING CYLINDERS, IN STEEL AND ALUMINIUM SPRING RETURN

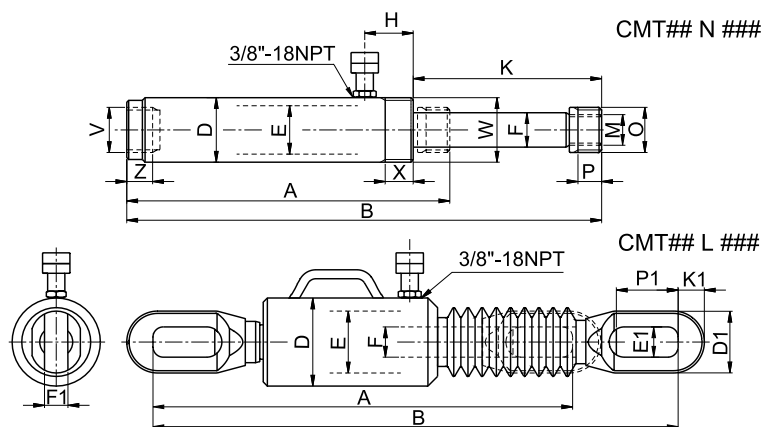

- Force **2-60 t**
- Stroke **127 - 150 mm**
- Max working pressure **700 bar**

Cylinders with non standard **force** and **stroke** can be supplied upon request

STEEL CYLINDERS SELECTION CHART

Pushing force	Stroke	Oil volume	MODEL	Closed height	Extended height	External Dia.	Piston Dia.	Rod Dia.	Coupler distance	Rod projection	Rod thread	Saddle thread	Saddle thread length	Internal base thread	Internal base thread length	Bodythread_Thread length	Weight
				A	B	D	E	F	H	K	M	O	P	V	Z	W/X	kg
2 22,9	127	41	CMT2N127	244	371	48	30	22	39	155	M18x1,5	3/4" NPT	18	3/4" NP	20	M40x1,5 20	2,9
5 55	140	110	CMT5N140	301	441	60	45	32	45	175	M30x2	1 1/4" NPT	22	1 1/4" NPT	24	M60x1,5 26	4,9
10 110	150	236	CMT10N150	302	452	80	55	32	39	189	M30x2	-	30	M30x2	25	M80x2 20	8,0

ALUMINIUM CYLINDERS SELECTION CHART

Pushing force	Stroke	Oil volume	MODEL	Closed height	Extended height	External Dia.	Piston Dia.	Rod Dia.	Eyelet width	Slit width	Eyelet thickness	Eyelet top thickness	Slit length	Weight
				A	B	D	E	F	D1	E1	F1	K1	P1	kg
10 110	150	236	CMT10L150	526	676	75	55	32	55	32	20	20	100	4,4
30 334		716	CMT30L150	612	762	128	90	45	90	44	34	38	100	13,2
60 559		1199	CMT60L150	734	884	168	120	65	107	61	40	50	140	33,5

* Nominal value, see kN for the exact force

MODEL CODING

CMT	10	N	###
Series	Pulling force in tonne	N = In steel L = In aluminium	Stroke in mm