

HIGH TONNAGE CYLINDERS, OIL RETURN

FEATURES

Solidly designed, the rod end has concentric grooves to improve load grip. Models above 30 tonne have lifting eyes, all models have anti-corrosive nitride treatment making them suitable for use in harsh environments.

A safety valve connected to the return chamber prevents any overpressure.

The end of stroke nut has a wiper to prevent the ingress of dirt.

They can operate with off-centred loads up to **8%** of their nominal capacity.



p. 43

ACCESSORIES

- **Separate ZTT tilt saddle**, to help combat possible side loading.



OPTIONS

- **T - Version**, cylinder with **integrated tilt saddle**.

F - Version, cylinder with base mounting **holes** for fixing purposes.



OPERATIONAL AREAS

Extremely solid hydraulic cylinders highly recommended for lifting, holding and lowering operations.

Ideally suited for use in civil and marine engineering applications and also in the construction industry.



p. 38



Where repetitive working cycles are needed or for use in presses, we recommend cylinders from the **COI** range.



p. 93

To ensure positive load holding we recommend installing the **VRP38** pilot check valve between the pump and cylinder.

HIGH TONNAGE CYLINDERS, OIL RETURN

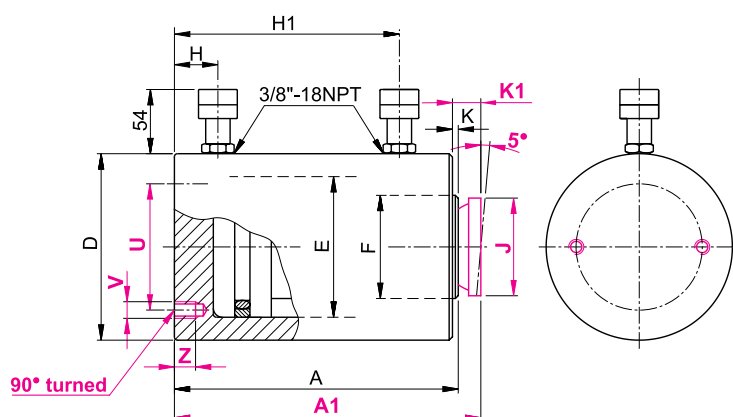

Force	50 - 500 t
Stroke	25 - 300 mm
Max working pressure	700 bar

Cylinders with non standard **force** and **stroke** can be supplied upon request

SELECTION CHART

Pushing force	Pulling force	Stroke	Pushing oil volume	Pulling oil volume	MODEL	Closed height	Closed height with integrated tilt saddle	External Dia.	Piston Dia.	Rod Dia.	Coupler height		Integrated tilt saddle Dia.	Rod projection with integrated tilt saddle	Rod projection with integrated tilt saddle	PCD mounting holes	Mounting holes_Depth	Weight
											H	H1						
t* kN	t* kN	mm	cm ³	cm ³		A mm	A1 mm	D mm	E mm	F mm	mm		J mm	K mm	K1 mm	U mm	V/Z mm	kg
50 496	15 144	50	354	103	COS50N50	149	154					104						14
		100	709	206	COS50N100	199	204	127	95	80	20	154	68	1	6	95	2xM12 15	18
		150	1063	309	COS50N150	249	254					204						22
100 929	38 379	50	664	271	COS100N50	171	178					124						30
		100	1327	542	COS100N100	221	228	175	130	100	28	174	88	2	9	130	2xM12 17	38
		150	1991	813	COS100N150	271	278					224						45
		200	2655	1084	COS100N200	321	328					274						52
150 1407	62 616	25	503	220	COS150N25	167	176					106						45
		50	1005	440	COS150N50	192	201					131						50
		100	2011	880	COS150N100	242	251	213	160	120	30	181	118	3	12	130	4xM12 17	61
		150	3016	1319	COS150N150	292	301					231						71
		200	4021	1759	COS150N200	342	351					281						82
		250	5027	2199	COS150N250	392	401					331						93

* Nominal value, see kN for the exact force

HIGH TONNAGE CYLINDERS, OIL RETURN

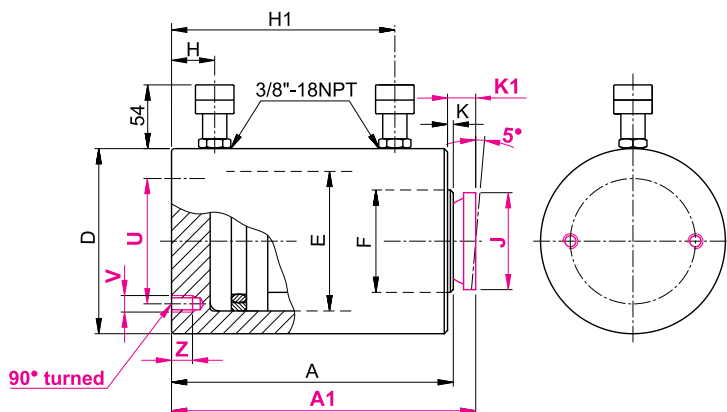

- Force 50 - 500 t
- Stroke 25 - 300 mm
- Max working pressure 700 bar

Cylinders with non standard **force** and **stroke** can be supplied upon request

SELECTION CHART

Pushing force	Pulling force	Stroke	Pushing oil volume	Pulling oil volume	MODEL	Closed height		External Dia.	Piston Dia.	Rod Dia.	Coupler height		Integrated tilt saddle Dia.	Rod projection with integrated tilt saddle	Rod projection with integrated tilt saddle	PCD mounting holes	Mounting holes_Depth	Weight	
						A	A1				H	H1							J
t* kN	t* kN	mm	cm ³	cm ³		mm	mm	mm	mm	mm	mm	mm	mm	mm	mm	mm	mm	kg	
200 1984	76 748	25	709	267	COS200N25	181	190					117						69	
		50	1418	534	COS200N50	206	215					142						76	
		100	2835	1068	COS200N100	256	265					192						92	
		150	4253	1602	COS200N150	306	315	252	190	150	32	242	148	3	12	140	4xM16 20	107	
		200	5671	2136	COS200N200	356	365					292							123
		250	7088	2670	COS200N250	406	415					342							138
		300	8506	3204	COS200N300	456	465					392							153
250 2424	85 835	25	866	298	COS250N25	197	206					128						92	
		50	1732	597	COS250N50	222	231					153						102	
		100	3464	1194	COS250N100	272	281					203						122	
		150	5195	1791	COS250N150	322	331	280	210	170	34	253	158	3	12	150	4xM16 20	141	
		200	6927	2388	COS250N200	372	381					303							161
		250	8659	2985	COS250N250	422	431					353							180
		300	10391	3581	COS250N300	472	481					403							200
300 2908	94 923	25	1039	330	COS300N25	203	212					130						113	
		50	2077	660	COS300N50	228	237					155						125	
		100	4155	1319	COS300N100	278	287					205						148	
		150	6232	1979	COS300N150	328	337	305	230	190	38	255	158	3	12	170	4xM16 20	172	
		200	8310	2639	COS300N200	378	387					305							195
		250	10387	3299	COS300N250	428	437					355							219
		300	12464	3958	COS300N300	478	487					405							242

* Nominal value, see kN for the exact force

HIGH TONNAGE CYLINDERS, OIL RETURN

SELECTION CHART

Pushing force	Pulling force	Stroke	Pushing oil volume	Pulling oil volume	MODEL	Closed height	Closed height with integrated tilt saddle	External Dia.	Piston Dia.	Rod Dia.	Coupler height	Integrated tilt saddle Dia.	Rod projection with integrated tilt saddle	Rod projection with integrated tilt saddle	PCD mounting holes	Mounting holes_Depth	Weight	
						A	A1	D	E	F		H	H1	J	K	K1		U
350 3436	103 1011	25	1227	361	COS350N25	210	222					132					138	
		50	2454	723	COS350N50	235	247					157					153	
		100	4909	1445	COS350N100	285	297					207					183	
		150	7363	2168	COS350N150	335	347	332	250	210	39	257	196	3	15	200	4xM16 20	213
		200	9817	2890	COS350N200	385	397					307						242
		250	12272	3613	COS350N250	435	447					357						272
400 4008	112 1099	25	1431	393	COS400N25	217	229					135					165	
		50	2863	785	COS400N50	242	254					160					182	
		100	5726	1571	COS400N100	292	304					210					215	
		150	8588	2356	COS400N150	342	354	356	270	230	42	260	196	3	15	230	4xM16 20	248
		200	11451	3142	COS400N200	392	404					310						281
		250	14314	3927	COS400N250	442	454					360						313
500 4948	154 1512	25	1767	540	COS500N25	225	237					140					212	
		50	3534	1080	COS500N50	250	262					165					232	
		100	7069	2160	COS500N100	300	312					215					271	
		150	10603	3240	COS500N150	350	362	396	300	250	50	265	196	3	15	250	4xM16 20	312
		200	14137	4320	COS500N200	400	412					315						352
		250	17671	5400	COS500N250	450	462					365						391
300	21206	6480	COS500N300	500	512					415						431		

* Nominal value, see kN for the exact force

ACCESSORIES: ZTT TILT SADDLES

MODEL	For use with	a	b	j	z	kg
ZTT50	COS50N ###	25	1	68	M8	0,9
ZTT100	COS100N ###	34	2	88	M10	1,7
ZTT150	COS150N ###	45	3	118		3,4
ZTT200	COS200N ###	54	3	148		7,0
ZTT250	COS250N ###	58		158	9,5	
ZTT300	COS300N ###			11,3		
ZTT350	COS350N ###	71	3	196	M12	18,0
ZTT400	COS400N ###					20,7
ZTT500	COS500N ###					23,8

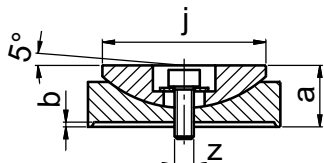

MODEL CODING

COS	50	N	###	#
Series	Pushing force in tonne	N = standard	Stroke in mm	F = with base mounting holes T = with integrated tilt saddle **

** Cylinders with a force below 100 tonne can be supplied subject to a minimum production batch, to be advised